

Régie Face

Console Accueil



Console Guest



AE-4D – AES / DANTE



MM-4D/IN – ANALOG / DANTE



ALMA



GigaCore 10 LU-0100058-P0E-NDM multimode Neutrik DUO



- Câble audio Symétrique
  - Câble Alimentation 230 V
  - Fibre optique
  - Câble réseau RJ45 VLAN 1
  - Câble réseau RJ45 VLAN 2
  - Câble réseau RJ45 VLAN 3 - ALMA
- 
- L ● R
  - L SUB ● R SUB
- ● Câbles DATA + AUDIO RJ45 – ALMA

GigaCore 10 LU-0100058-P0E-NDM multimode Neutrik DUO



Jardin



Scène



Cour

GigaCore 10 LU-0100058-P0E-NDM multimode Neutrik DUO



NS-VMX88



NS-VMX88



Scène

Jardin

Cour

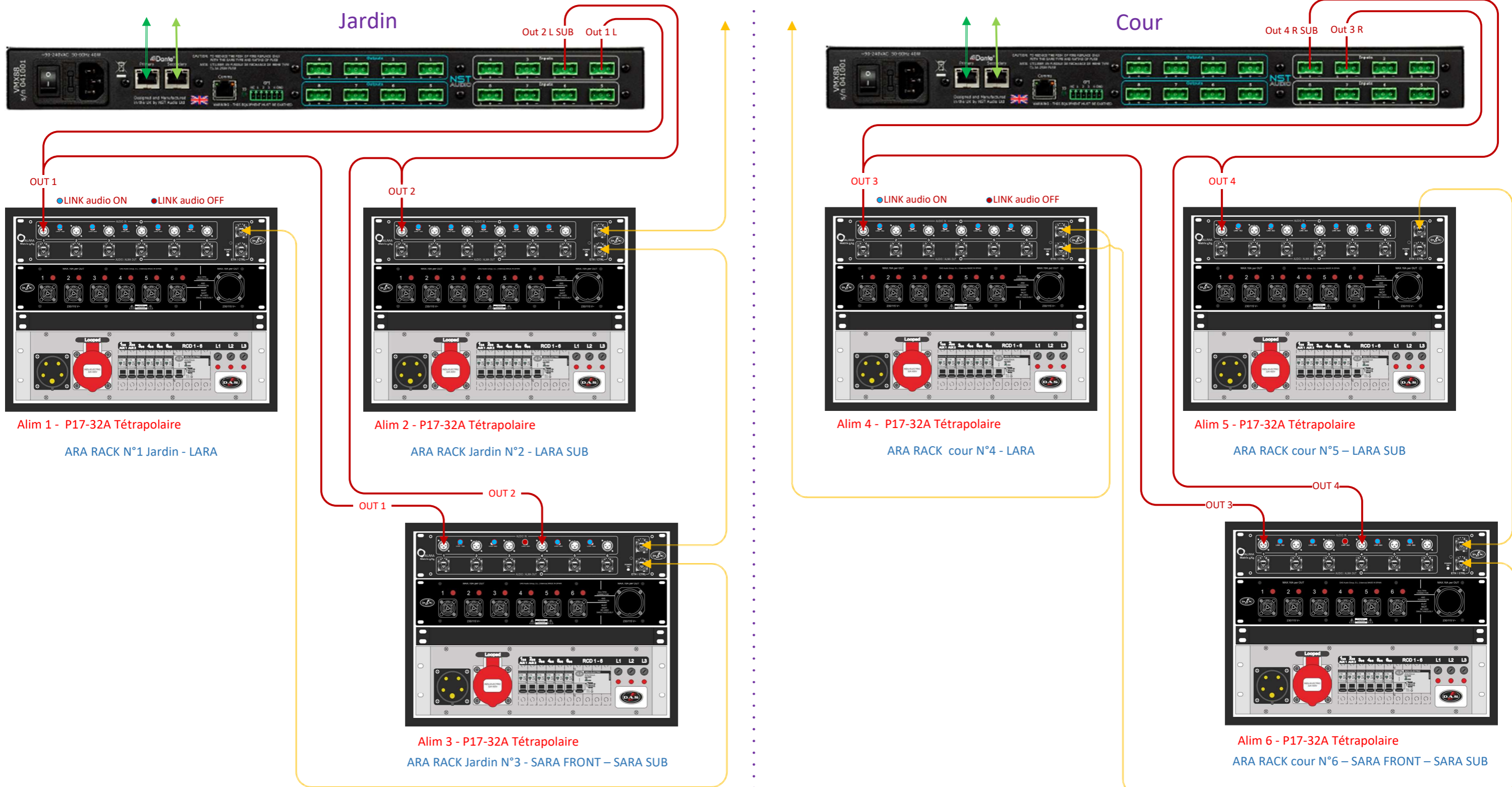

Jardin

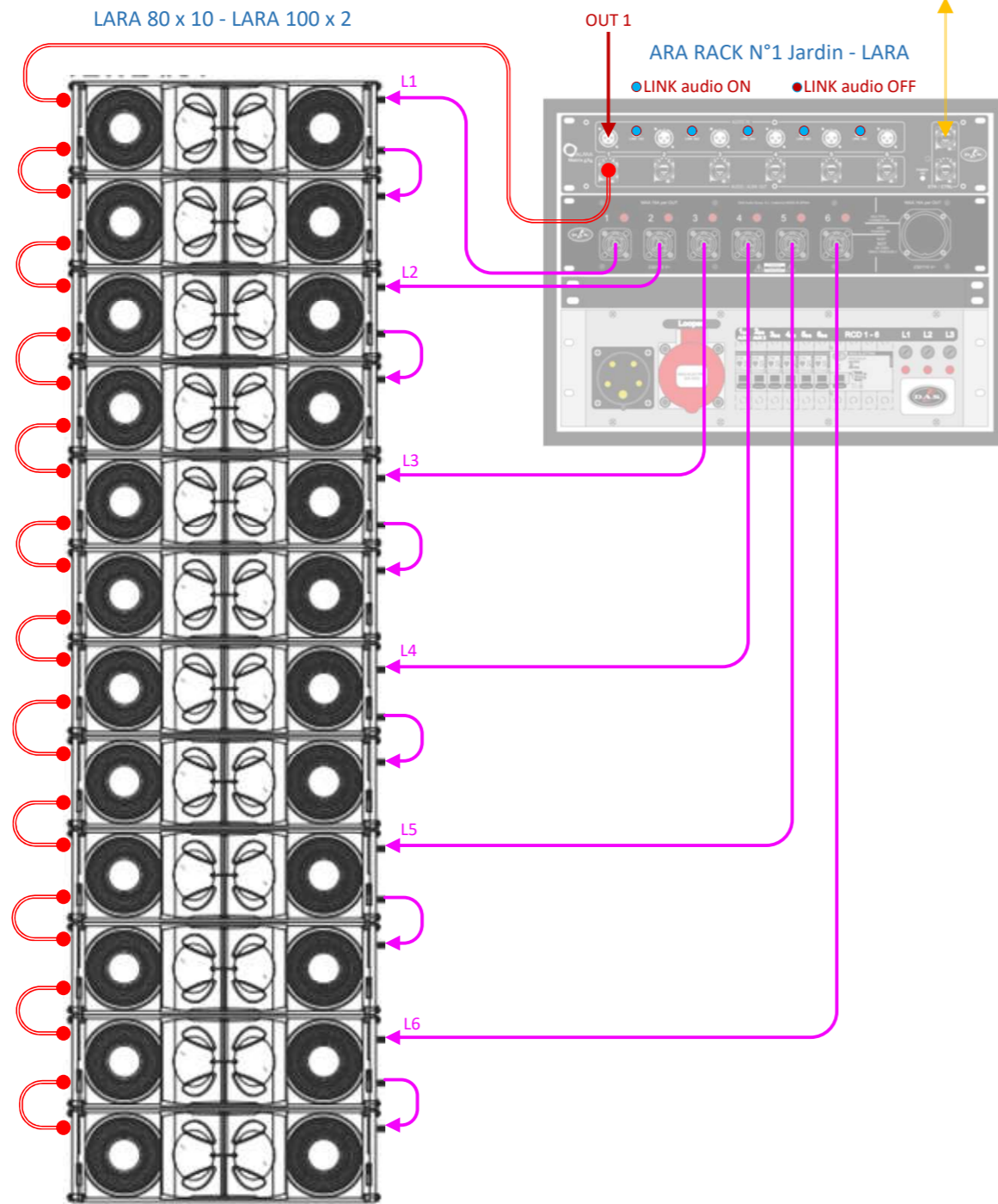

Scène

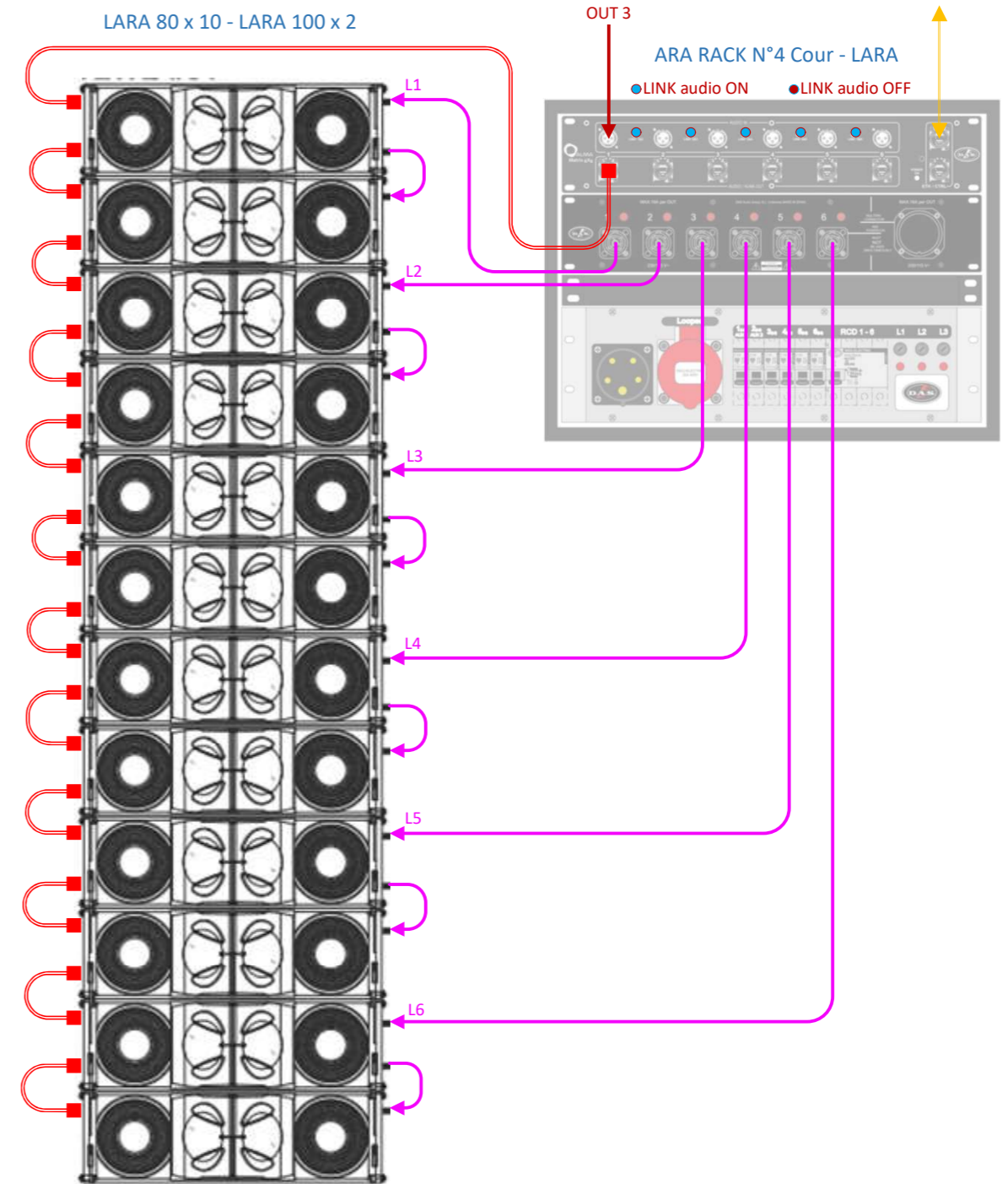

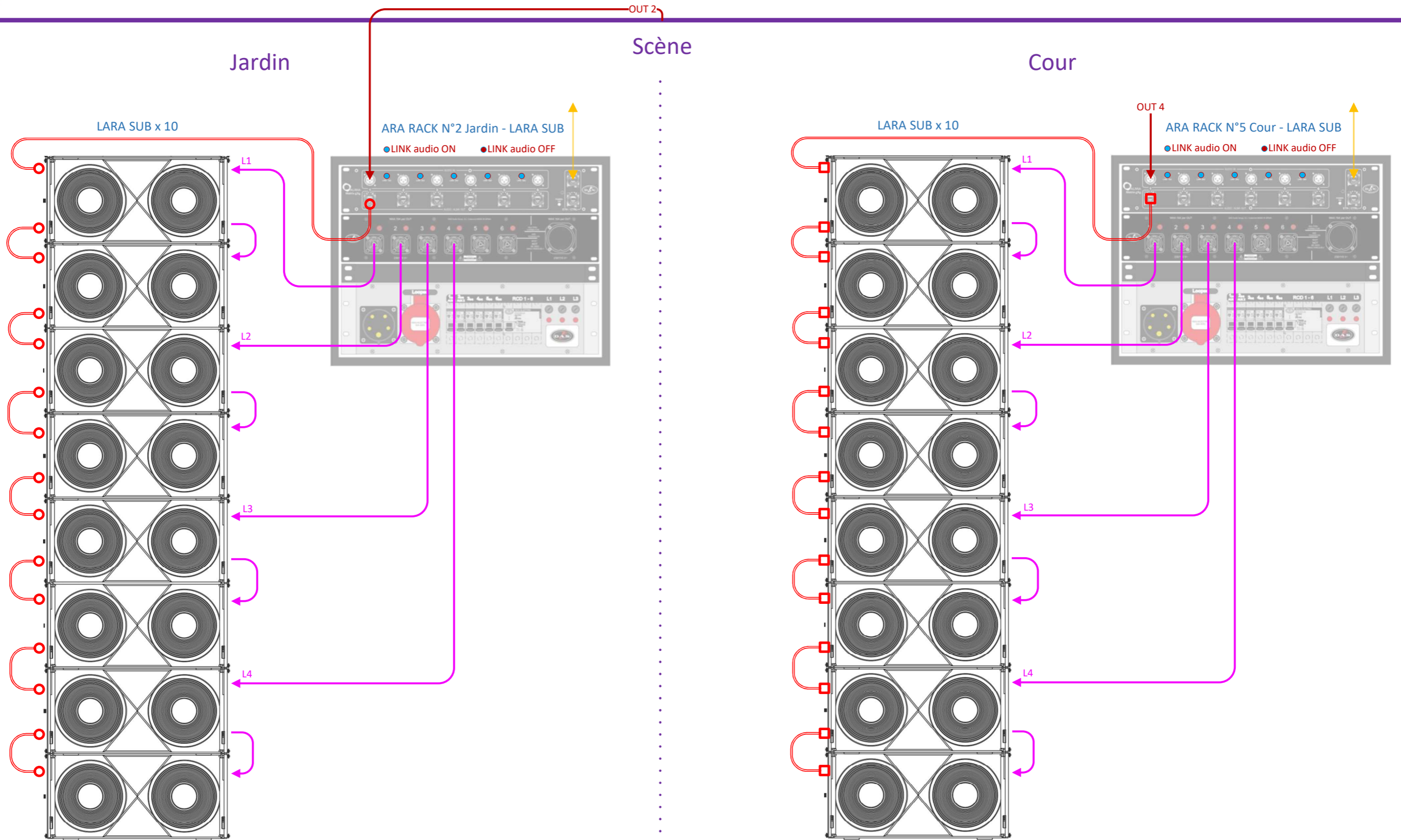

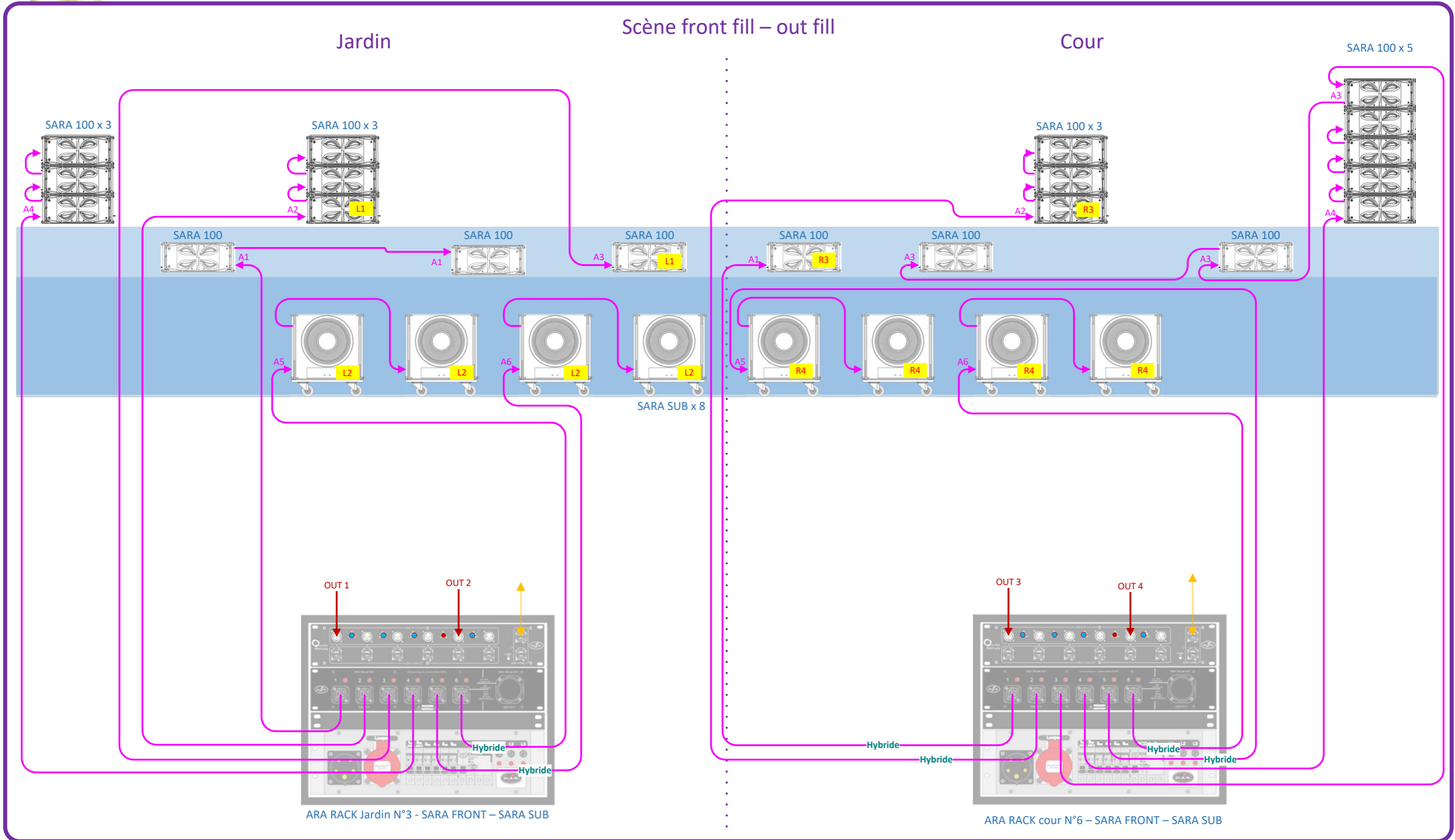

Jardin

Scène front fill – out fill

Cour

SARA 100 x 2

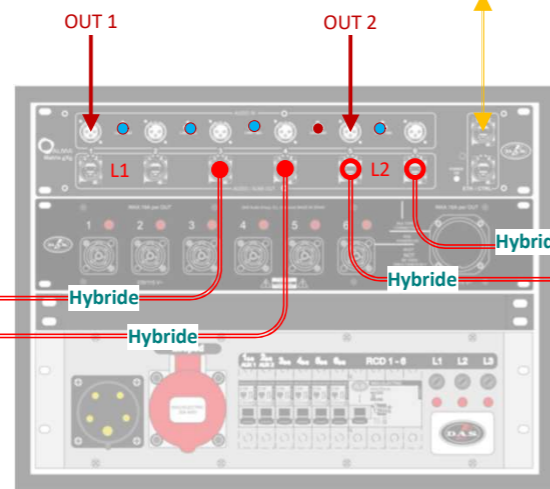
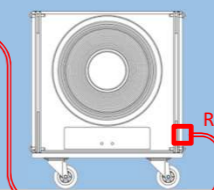
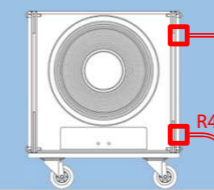
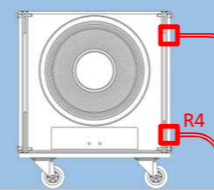
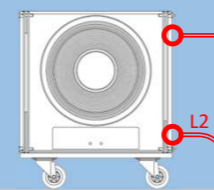
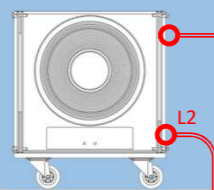
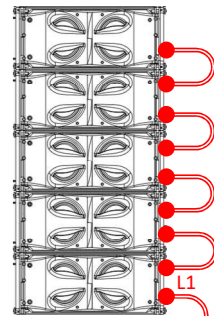
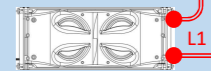
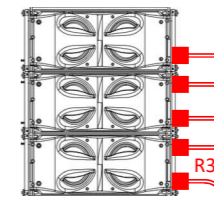
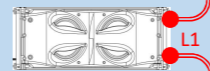
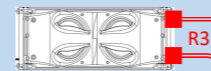
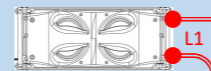
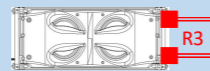
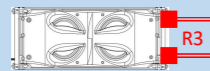
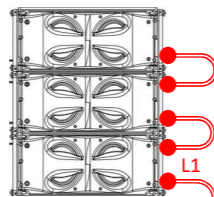
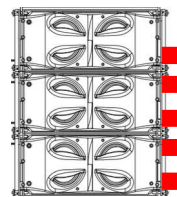

ARA RACK Jardin N°3 - SARA FRONT – SARA SUB

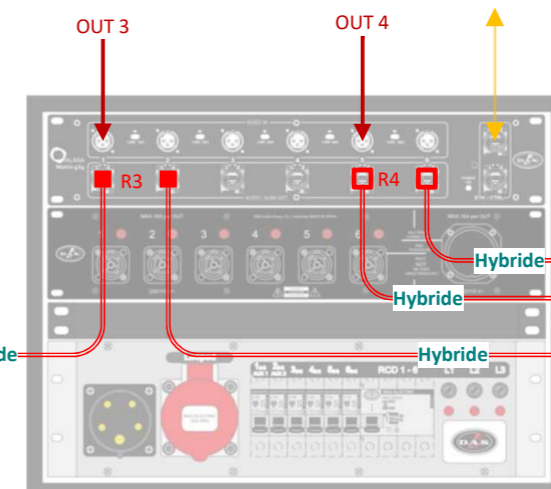

ARA RACK cour N°6 – SARA FRONT – SARA SUB

ARA RACK Jardin N°3 - SARA FRONT – SARA SUB

ARA RACK cour N°6 – SARA FRONT – SARA SUB

### Scène arc sub

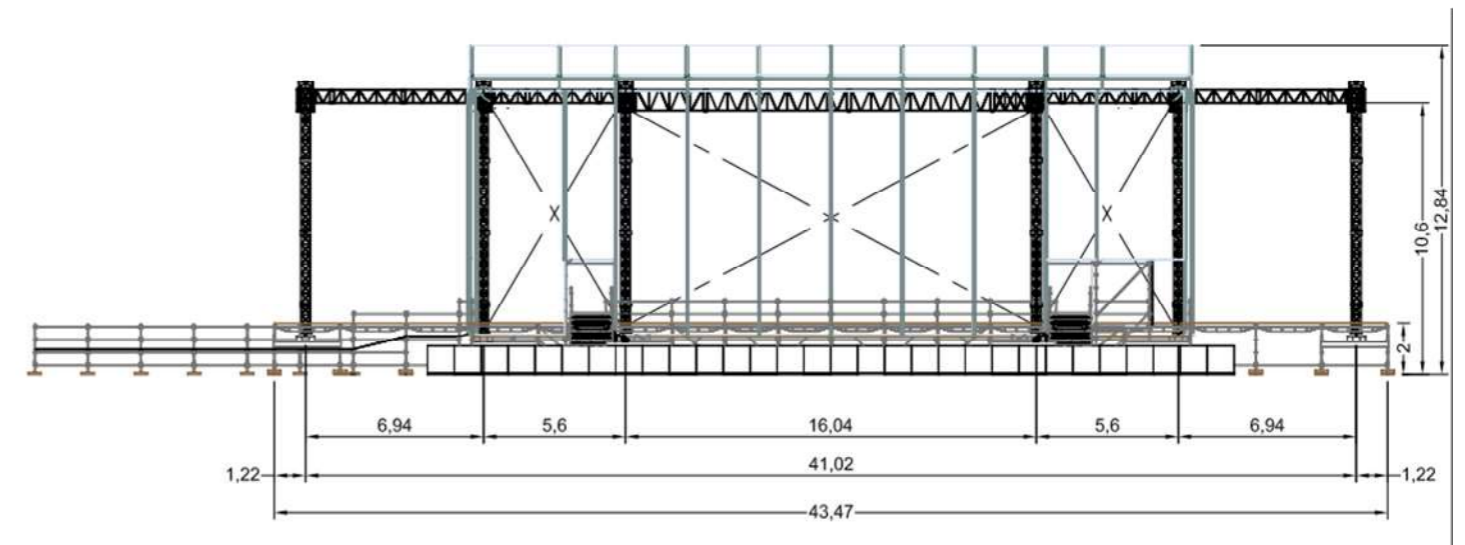
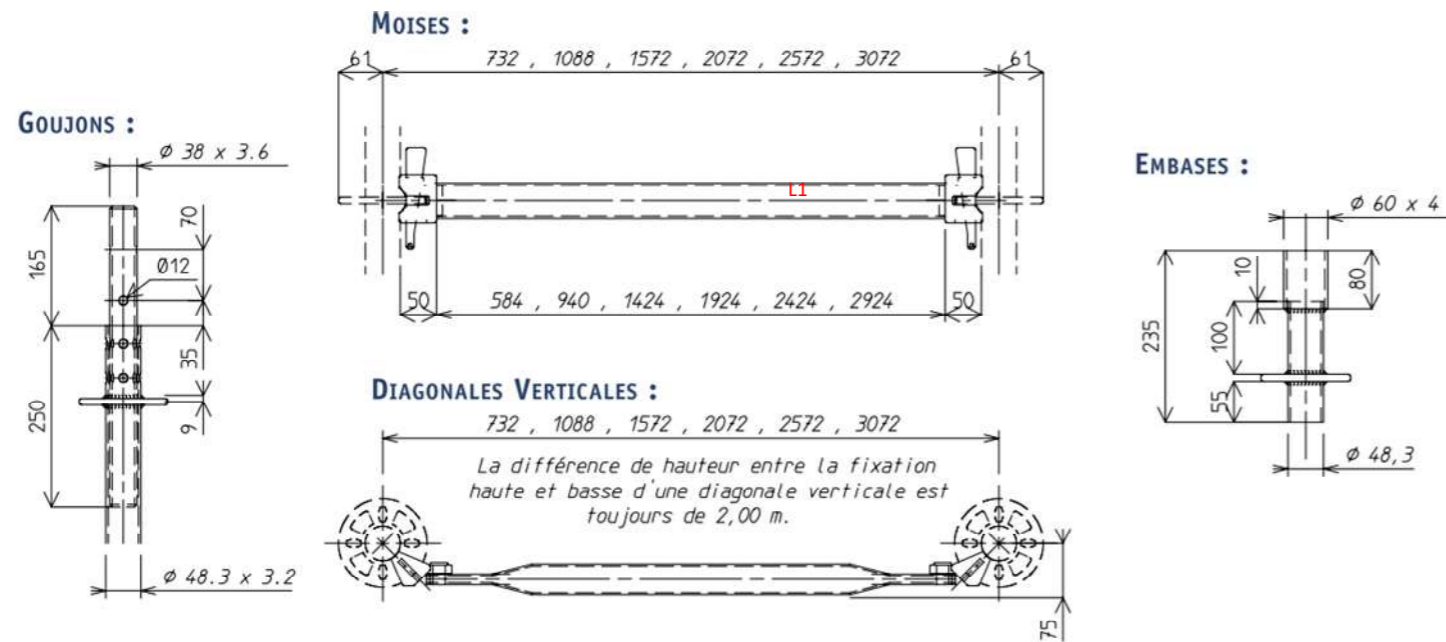

### Jardin

### Cour

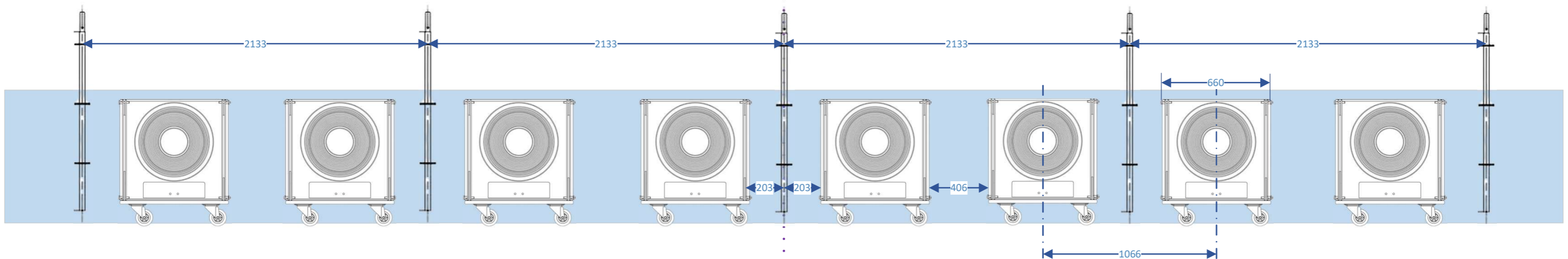

## Scène arc sub

### 1 Informations sur le projet

Titre du projet:	Foire en Scène 2023
Date:	Vendredi 28 juillet 2023
Auteur:	Cédric Mercier
Société:	AUDIOPOLE - CSI AUDIOVISUEL
Remarques:	27-07/2023
Température:	20,0°C
Pression:	Standard (1010 hPa)
Humidité:	Standard (60%)
Mapping:	50 Hz (1 Octave) - Sans pondération

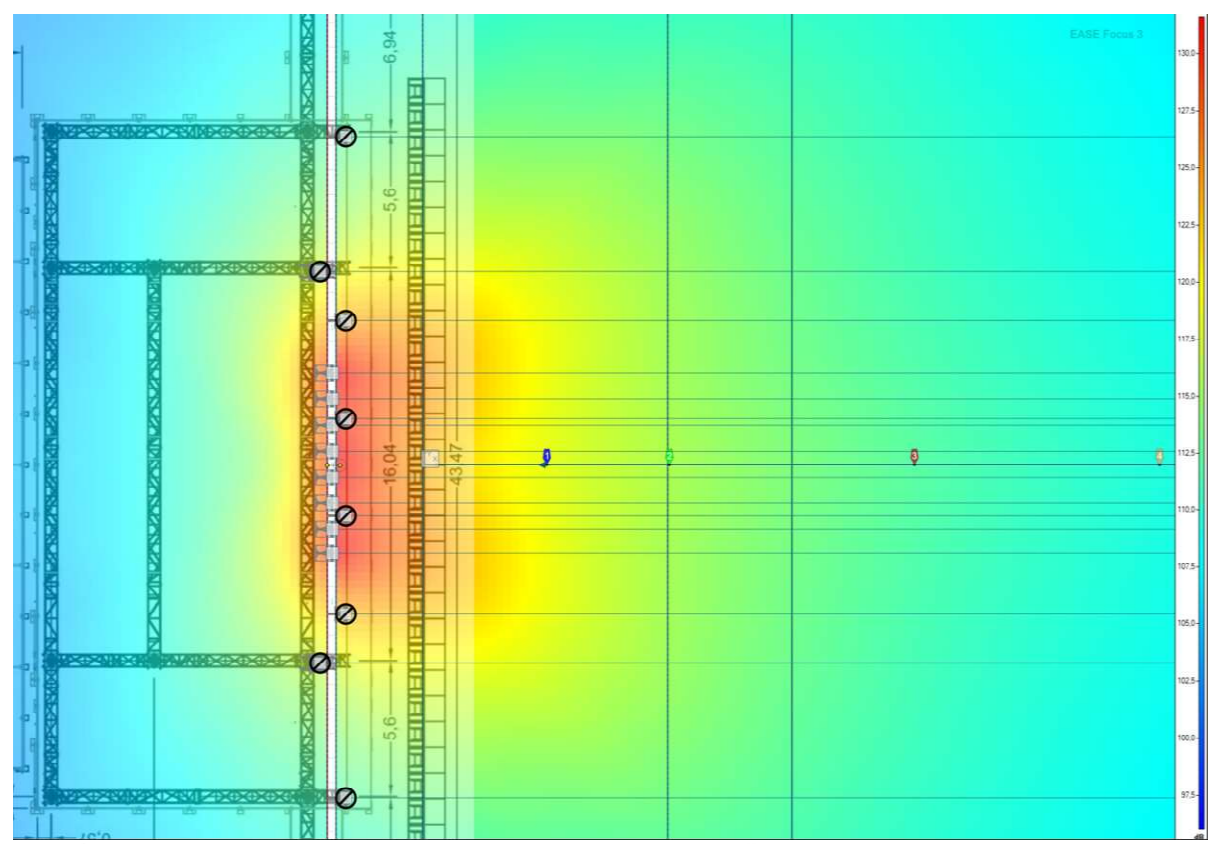

### 2 Sources sonores

Nom	Type	Système	X [m]	Y [m]	Z [m]	Hor [°]	Ver [°]	Rot [°]
1 SARA proscenium J1	Line Array	SARA	-3,21	-2,14	2,10	0,0	0,0	0,0
2 SARA proscenium J2	Line Array	SARA	-3,21	-6,14	2,10	0,0	0,0	0,0
3 SARA proscenium J3	Line Array	SARA	-3,21	-13,64	2,10	0,0	0,0	0,0
4 SARA proscenium R1	Line Array	SARA	-3,21	1,86	2,10	0,0	0,0	0,0
5 SARA proscenium R2	Line Array	SARA	-3,21	5,86	2,10	0,0	0,0	0,0
6 SARA proscenium R3	Line Array	SARA	-3,21	13,36	2,10	0,0	0,0	0,0
7 SARA SUB L1	Line Array	SARA	-3,76	-0,55	0,85	0,0	0,0	0,0
8 SARA SUB L2	Line Array	SARA	-3,76	-1,61	0,85	0,0	0,0	0,0
9 SARA SUB L3	Line Array	SARA	-3,76	-2,68	0,85	0,0	0,0	0,0
10 SARA SUB L4	Line Array	SARA	-3,76	-3,66	0,85	0,0	0,0	0,0
11 SARA SUB R1	Line Array	SARA	-3,76	0,53	0,85	0,0	0,0	0,0
12 SARA SUB R2	Line Array	SARA	-3,76	1,59	0,85	0,0	0,0	0,0
13 SARA SUB R3	Line Array	SARA	-3,76	2,66	0,85	0,0	0,0	0,0
14 SARA SUB R4	Line Array	SARA	-3,76	3,72	0,85	0,0	0,0	0,0
15 SARA VIP cour	Line Array	SARA	-4,76	19,86	2,55	8,8	17,0	0,0
16 SARA x 3 cour	Line Array	SARA	-4,26	7,86	2,00	0,0	8,8	0,0
17 SARA x 3 Jardin	Line Array	SARA	-4,26	-8,14	2,00	0,0	8,8	0,0
18 SARA x3 VIP jardin	Line Array	SARA	-4,76	-20,14	2,55	-28,7	-4,9	0,0

